



ELM Earth Leakage Protection Relay



Designed and Manufactured in Australia by
Ampcontrol Pty Limited ACN 000 915 542
Phone: (02) 4956 5899 Fax: (02) 4956 5985
www.ampcontrol.com.au

No copies of the information or drawings
within this manual shall be made without
the prior consent of Ampcontrol.

USER MANUAL

121408 ISSUE 4 15/02/11

ELM_Manual_Issue_4_121408_150211.pdf

CRN: 8274

Copyright Notice

No part of this publication may be reproduced, transmitted or transcribed into any language by any means without the express written permission of Ampcontrol Pty Ltd, 250 Macquarie Road Warners Bay, NSW 2282, Australia.

Disclaimer

Ampcontrol Pty Ltd will make no warranties as to the contents of this documentation and specifically disclaims any implied warranties or fitness for any particular purpose.

Ampcontrol further reserves the right to alter the specification of the system and/or manual without obligation to notify any person or organisation of these changes.

Before You Begin

We would like to take a moment to thank you for purchasing the ELM Earth Leakage Relay. To become completely familiar with this equipment and to ensure correct operation, we recommend that you take the time to read this user manual thoroughly.

1. Protection Systems1

2. The Need for Earth Leakage Protection1

2.1 Earth Leakage Systems2

2.2 Methods of Earth leakage Protection.....2

2.3 Core Balance Protection2

2.4 Series Neutral Protection2

2.5 Earth Leakage Toroids.....3

2.6 Toroid Selection.....3

2.7 Toroid Installation Guidelines3

3. ELM Earth Leakage Relay

3.1 Description.....4

3.2 Methods of Earth Leakage Protection.....4

3.3 Testing Procedure4

3.4 Toroids.....4

3.5 Mode of Operation.....4

4. Specifications5

5. Equipment List.....5

6. Diagrams

ELM Typical Installation Diagram6

Core Balance E/L System7

Series Neutral E/L System8

Mounting Details.....9

1. Protection Systems

Earthing of electrical equipment, associated machinery and structures is a seemingly simple practice and is covered adequately by the various applicable sections of Australian Standards AS3000 or AS3007.

However, in the mining industry earthing is somewhat more complex than normal domestic or commercial applications and requires other factors to be taken into consideration particularly where trailing and/or reeling cables supply mobile electrical equipment.

The protection systems are designed to provide touch and step potentials of 50 Volts or less when all the systems are used collectively.

It should be clearly understood that unless all four types of protection is incorporated in any design, then personal protection (touch and step potentials of 50V or less) will need to be assessed by a competent person or authority.

The protection systems that cover coal and shale mines are detailed in AS2081, Part 1 to 5. Although these standards do not apply to metalliferous mining they are a good benchmark to follow.

Part 1: General requirements for electrical protection devices for use in coal and shale mines.

Part 2: Earth Continuity monitoring devices.

Part 3: Earth Leakage protection devices.

Part 4: Lockout Earth fault devices (test before energisation)

Part 5: Earth Fault Limitation (impedance earthing)

The above standards are not a stand-alone group and have been developed in co-ordination with other standards being:

1. AS1740 – Underground mining substations
2. AS1802, AS1300 – Reticulation, trailing and reeling cables
3. AS1299, AS1300 – Plugs, adaptors, couplers and receptacles
4. Internationally accepted voltage/time effects on the human body based on IEC479
5. Installation in accordance with accepted State and Federal Regulations

6. Equipment maintained in accordance with industry standards

2. The Need for Earth Leakage Protection

Unless properly controlled the occurrence of an earth fault can be hazardous because it may cause:

- a) Frame to earth voltages dangerous to personnel.
- b) Electric arcing, which may initiate an explosion or fire when arcing occurs in an underground mining operation.

The main purpose of earth fault protection is to safeguard personnel and electrical apparatus. However it is found that relays designed to operate on fault limited systems are not suitable for personal protection, i.e. users of portable drills, grinders etc, which require trip levels of 20-30mA, with instantaneous operation. (Refer AS3190).

The most common apparatus faults in mining applications are cable faults. Cables are most susceptible to damage and are the major source of dangerous electrical incidents. This applies particularly to the flexible trailing cables supplying power to mobile mining machines.

Cable construction is such as to provide every phase conductor with an individual conductor screen so that crushing would cause a low single phase to earth fault current. The protective device, such as an Ampcontrol ELM earth leakage relay, would then isolate the cable and contain the sparking within the cable before a heavy short circuit current due to a phase to phase fault occurs.

Earth fault protection has been applied with considerable success in limiting faults and providing quick disconnection of electrical apparatus from the supply in the event of earth fault situations.

A definite time operating characteristic is provided with adjustable trip sensitivity and time delay.

Time delay between protective units is introduced to allow the unit close to the fault to isolate the faulty circuit without causing the healthy part of the system to be de-energised.

2.1 Earth Leakage Systems

Desirable though it may be, it is impractical to provide automatic protection against electrocution as a result of direct contact with a live conductor, particularly where the electrical reticulation is exposed to a humid or damp atmosphere.

Table 1 indicates the current values affecting human beings.

Current mA	Symptom
1 or less	Causes no sensation - not felt
1 to 8	Sensation of shock, not painful, individual can let go at will, as muscular control is not lost
8 to 15	Painful shock, individual can let go at will, as muscular control is not lost
15 to 20	Painful shock, muscular control of adjacent muscles lost, cannot let go
20 to 50	Painful, severe muscular contractions, breathing difficult
50 to 100 (Possible) 100 to 200 (Certain)	Ventricular fibrillation (a heart condition that may result in death)
200 and over	Severe burns, severe muscular contractions that are so severe that chest muscles clamp the heart and stop it for the duration of the shock. (This prevents ventricular fibrillation)

Table 1

It will be seen from the foregoing table that the passage of a current of as low as 15mA through the human body can cause loss of muscular control to the extent of preventing the recipient from disengaging from the live conductor. Whereas a current in excess of 50mA is sufficient to produce a critical heart condition from which there is little or no chance of recovery.

It follows that as an effective safeguard against electrocution resulting from direct contact with a live conductor, it would be necessary to introduce earth leakage protection designed to operate with a fault current below 15mA, which in the majority of cases, would be impractical.

The automatic protection of circuits is not intended to take the place of sound installation practice and the regular maintenance and testing of electrical apparatus.

Care must be taken in the selection and installation of all electrical equipment with due regard to its required duty and the conditions under which it may be called upon to operate.

Where automatic earth leakage protection has been installed it is essential that its operation be tested often and to facilitate this a means for testing is incorporated in all approved earth leakage relays.

2.2 Methods of Earth Leakage Protection

Earth Leakage Protection Relays for use in mining applications have to be designed with reference to AS2081 for use on fault-limited systems.

There are two methods of protection used. They are the Core Balance and the Series Neutral earth leakage protection systems. The Core Balance relay performs the primary protection in an installation protecting the outlet supplying power to a machine. In this application the time delay is set at instantaneous. The neutral earth leakage relay is the back up relay of the installation.

2.3 Core Balance Protection

With this method the three phases are passed symmetrical through the toroid. If there is no earth fault present, the vector sum of the currents in a three-phase supply is zero. If current from any phase flows to earth the system becomes unbalanced. The toroid produces an output, which trips the relay.

A test current is injected through the window of the toroid to test the operation of the relay. See typical circuit, Page 7.

2.4 Series Neutral Protection

With this method the neutral is passed through the toroid. An earth fault on any of the phase conductors causes an earth current which returns, through the toroid, to the star point of the transformer.

A test circuit can connect a test resistor between a phase and earth or inject a current through the toroid as previously described. The test resistor to earth method is recommended

with this type of protection as this test also proves the neutral to earth connection. See typical circuit, Page 8.

2.5 Earth Leakage Toroids

Toroids (current transformers) are not ideal devices and if correct procedures are not followed during installation nuisance tripping can result. If, for example, we consider a single-phase earth leakage system where active and neutral pass through a toroid then at all times currents in the two wires are equal and opposite so that the net current through the toroid is zero. An ideal current transformer would have all of the flux from each wire contained in the core and so would accurately add the opposing fluxes to get a net result of zero. A real current transformer has “leakage fluxes”. That is, a very small proportion of the total flux from each cable is not contained in the core but in the space outside it and as a result it may link some turns but not others, depending on the positioning of the cables. The effect of this is that a small output may be obtained from the toroid where none would arise if the device were ideal.

The size of the error may vary from toroids of the same type because of slight differences in the core and the symmetry of the winding. Problems caused in this way increase as the toroid size increases, as currents increase and symmetry decreases. Nuisance tripping tends to occur when the total current rises, such as when a large motor is started. The following guidelines would help to avoid such problems.

2.6 Toroid Selection

1. Select the smallest internal diameter toroid, which will allow the cables to fit through. Avoid very large toroids (200mm) or toroids with square apertures.
2. Only use approved toroids specified by Ampcontrol as these have been designed to minimise the problem.

2.7 Toroid Installation Guidelines

1. Keep cables as close to the centre of the toroid as possible. Do not tie them to one side of the toroid. Remember to aim at symmetry
2. Do not bring the cables back past the toroid within one diameter of the toroid.

Trying to cram cables into a small space reduces symmetry and may lead to problems, which are difficult to solve.

3. Avoid placing the toroid near any device, which produces magnetic fields. This includes bus bars, transformers or other cables. Try to maintain several toroid diameters clearance.
4. Many small cables tend to be worse than say three large ones. Try to position the toroid in the circuit with this in mind.
5. Toroids used for core balance earth leakage protection cannot have bus bars passed through the toroid.

To prevent possible nuisance tripping it is suggested that the conductor screen of the earth leakage toroid should be earthed one end only, the relay end. If both ends are earthed the possibility exists for the shield to become an earth loop, having finite resistance and injecting noise into the toroid leads.

3. ELM Earth Leakage Relay

3.1 Description

The Ampcontrol ELM Earth Leakage Relay is electronic in design and is based on microprocessor technology. The 'Healthy' LED flashes to indicate correct operation of the microprocessor. The Relay uses a toroid to measure earth fault current. A definite time operating characteristic is provided with adjustable trip sensitivity and time delay. When a fault occurs and the trip level and time delay is exceeded the relay's trip function is activated, operating the trip contacts connected in the system control circuit. The 'Trip' LED is 'On' when a trip occurs. The trip condition is latched in non-volatile memory and requires operation of the reset input to clear the trip condition. An internal reset is also provided on the facia of the relay. The 'Relay' LED is 'On' to indicate the relay is energised.

A ten-segment LED bar graph indicates the % of leakage level being detected. This reading can be remotely monitored/displayed using the 4-20mA Output of the Relay. When the relay measures currents with frequencies much greater than 50Hz the bar graph LED fast flashes (5Hz) instead of being steady. Should the high frequency current persist until the time delay is exceeded the relay will trip. The 'Har.Trip' LED (Harmonic Trip) is 'On' when a trip occurs.

The ELM Earth Leakage Relay is housed in a stainless steel case and can be either 'DIN Rail' mounted or 'Panel Mounted' through a 69 x 39mm cut out. When panel mounted the front of the ELM Relay is designed to provide IP-56 ingress protection. There is provision to prevent unauthorised adjustment of the trip settings by sealing the post (in front of the knurled nut) with a lead seal, thus preventing the removal of the front facia cover.

An internal switch mode power supply allows the ELM to operate from 24VAC to 132VAC or 20VDC to 185VDC.

The ELM Relay has been designed and tested for use on fault-limited systems. To ensure maximum protection the earth leakage system should be used in conjunction with the other protection systems covered by AS2081. The collective systems are designed to limit touch and step potentials.

The relay is also suitable for industry where equipment or system earth leakage protection is required. The relay is not suitable for personal protection, which requires trip levels of 20-30mA, with instantaneous operation. (Refer AS3190).

The ELM Relay continually monitors the toroid and if the connection is lost the relay will trip and flash the 'CT Fault LED'.

3.2 Methods of Earth Leakage Protection

The ELM Relay is suitable for the two methods of protection used. They are the Core Balance and Series Neutral earth leakage protection systems. (See previous section for details).

3.3 Testing Procedure

A test current is injected through the window of the toroid to test the operation of the relay (See typical connection diagram, Page 6). To reset the relay press the button located on the facia of the relay or provide an external normally open contact (it is recommended that a twisted pair be used between the N/O contact and the reset input). The reset button is also used to access the memory of the processor to view the maximum level of leakage since the previous trip. A section of the bar graph will slow flash (2Hz) indicating the peak level while, the reset button is held closed and will continue to flash for 1 second after the reset button is released.

3.4 Toroids

The ELM Relay is designed for use with Ampcontrol EL500S series Toroids. They are available with window sizes 25, 60 & 85mm. These allow trip settings from 100mA to 2.5A.

3.5 Mode of Operation

The relay can be operated in fail-safe or non-fail safe modes of operation.

Fail Safe Mode:

This mode is the default and preferred method, where the relay drops out on fault or loss of power. Power to the relay is from the line side of the isolating device or from an independent supply.

Non Fail Safe Mode:

In this mode of operation the relay picks up on fault. This method should only be used when the supply to the relay is only available from the load side of the isolating

device. To select this mode link the 'NFS' input terminals ('NFS' LED is 'On' when this mode is selected).

Note1: To restore power following a trip condition the reset needs to be held while re-closing the circuit breaker.

4. Specifications

Relay Supply Volts:

24 –132VAC, 20-185VDC

4-20mA Output:

The 'Loop Powered' current output represents the leakage current as a percentage of the trip level.

4mA => 0% leakage, 20mA =>120% leakage
(100% = 17.33mA)

Maximum Loop Resistance = $[V_s - 10] \times 50$, where V_s must be greater than 10VDC and less than 30VDC.

Relay Contacts:

1 N/O, 1 C/O. Rated at 5A 250V, 100VA maximum.

Trip and Time Delay Settings:

Two separate rotary, 16 position switches, set the trip and time delay parameters of the relay

Switch Position	Trip Level mA	Time Delay mS
0	100	50
1	150	100
2	200	150
3	250	200
4	300	250
5	350	300
6	400	350
7	450	400
8	500	450
9	750	500
A	1000	750
B	1250	1000
C	1500	1500
D	1750	2000
E	2000	2500
F	2500	3000

Dimensions: 47 H x 77 W x 116 D mm

5. Equipment List

121398	ELM Earth Leakage Relay
101399	ELD DIN Rail Mounting Kit
120255	ELD-ELC/F Adapter Kit
115438	Toroid - EL500S 25mm ID
115439	Toroid - EL500 / 60mm ID
115440	Toroid - EL500 / 85mm ID
115441	Toroid - EL500 / 112mm ID

Typical Connection Diagram

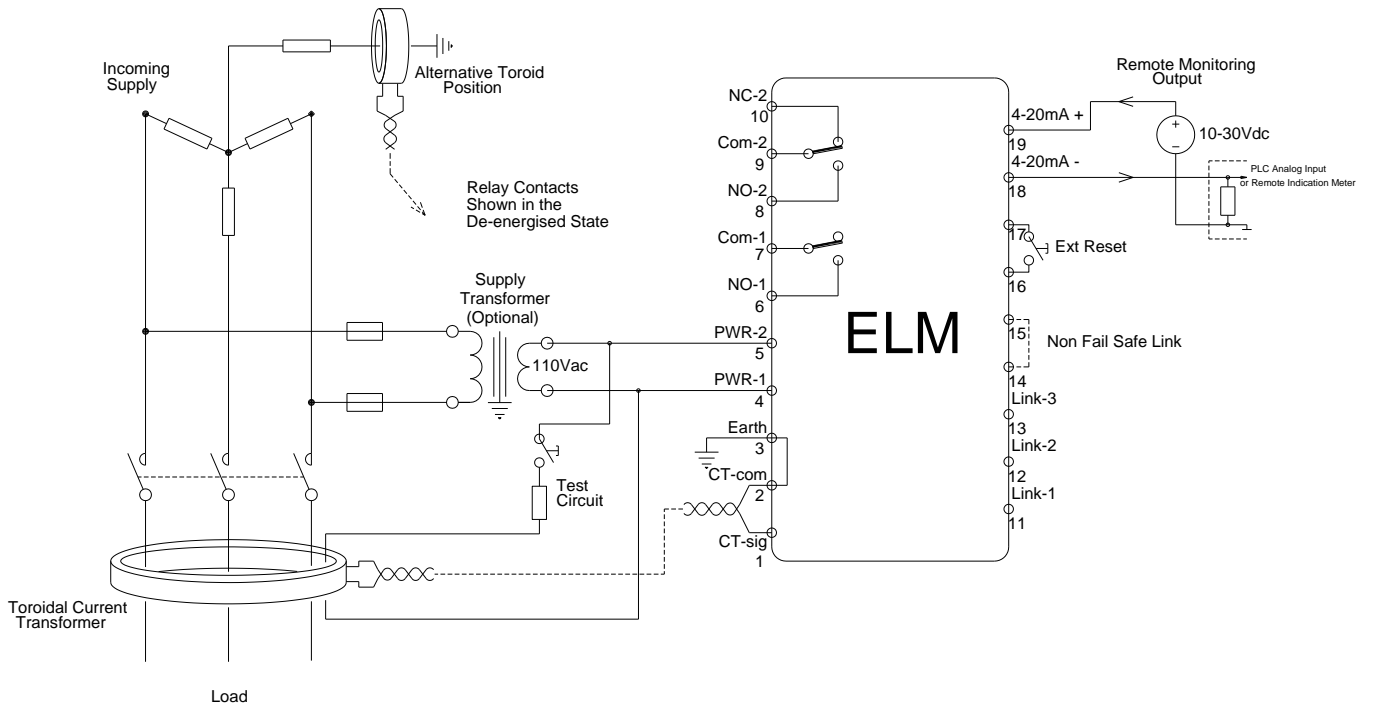

CORE BALANCE EARTH LEAKAGE PROTECTION

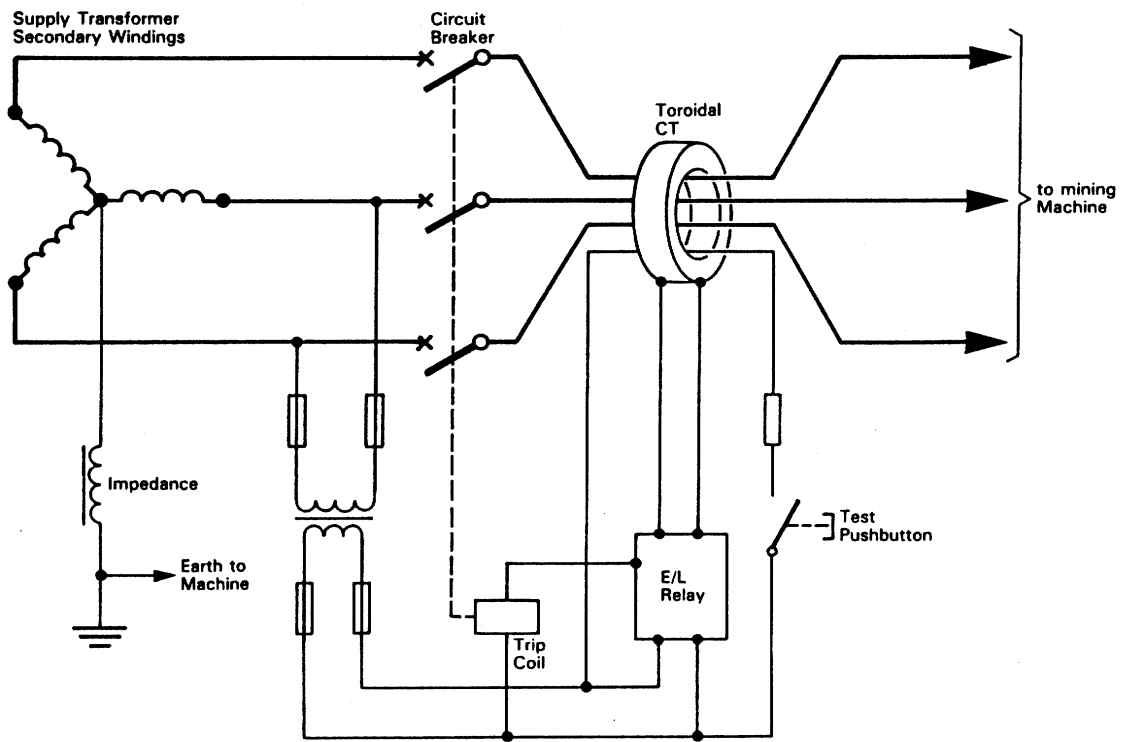

SERIES NEUTRAL EARTH LEAKAGE PROTECTION

